

Lifting Clutch

PRODUCT DESCRIPTION

These strong, safe, lightweight clutches suit all spherical head lifting anchors. They protect against dangerous disconnection where there is a risk of fouling which is a common problem when lowering precast drainage products in confined spaces like trenches.

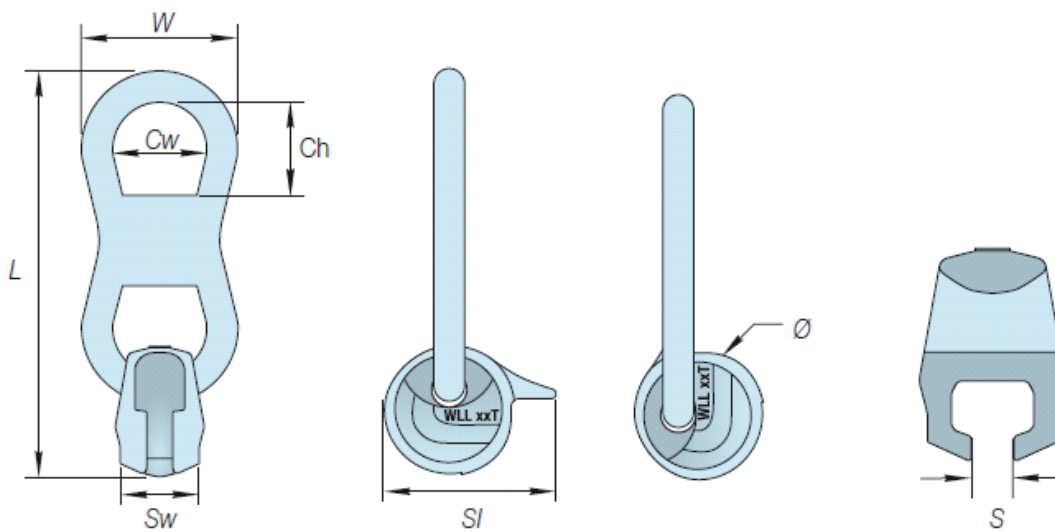

WORKING LOAD LIMITS

WLL	Annual Proof Load kN	Nominal WLL Anchor	Part Code
2	24	1.3	01LK
3	36	2.5	02LK
5	60	5	05LK
10	120	10	10LK
20	240	20	20LK
32	384	32	32LK

Part Codes and Nominal Dimensions

Part Code	L	W	Ch	Cw	Sw	Sl	∅	S
01LK	170	66	44	40	33	72	56	11
02LK	215	85	59	52	42	88	68	16
05LK	270	110	62	70	57	113	88	22
10LK	365	145	83	90	73	144	112	31
20KJ	515	210	103	130	110	195	152	43
32LC*	680	272	189	172	160	300	180	52

*Halfen clutches carry a CE mark, more information is available on request

A 5 tonne remote release Locking Klaw Is also available which is ideal for tilt - up construction.

Product Description Code	Part
5 Tonne Remote Release	05LKRR