

PRODUCT DESCRIPTION

Concrete cover (the zone between reinforcement and concrete surface) protects reinforcement against aggressive environmental elements. Cover concrete must be as dense and as hard as possible to prevent surface degradation and the ingress of aggressive elements to the reinforcement. Bridges, for example, are exposed to these aggressive elements: oxygen, carbon dioxide, humidity, wind, sand and mineral salts. Due to the poor quality of concrete surfaces, visible damage to the concrete can occur after only a few years. The use of Zemfrasa with self-adhesive backing modifies the surface characteristics of the concrete which considerably improves all concrete properties increasing quality and durability.

*Zemfrasa and Zemdrain®MD are the same product, except Zemfrasa has added self-adhesive backing.

BENEFITS

- Self-adhesive backing
- Smooth to slightly textured, which surface (concrete side)
- Rear side (formwork side) with special draining grid
- Roll dimensions: width 2.5m and length 35m
- Very economic because of the possibility of repeated use (2-3 times), simple and quick assembly
- High water storage capacity, therefore also suited for inclined or horizontal surfaces

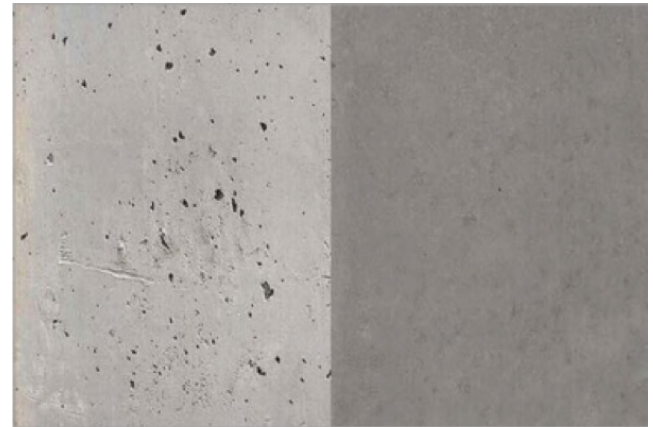

without Zemdrain®

with Zemdrain®

AREAS OF APPLICATION

Zemdrain® of all types consists of a filter layer consisting of polypropylene fibres with a highly controlled pore structure that ensures retention of cement and fine aggregate but is permeable to water and air. Adhesion of the filter to the concrete is minimal. The rear of the liner is a drainage layer consisting of either polypropylene fibres or a special grid. Zemdrain® is widely used for various applications:

- Drinking Water Structures
- Wastewater & Sewage Treatment Plants
- Marine & Waterways Structures
- Dams & Power Stations
- Transport Infrastructure
- Exposed concrete

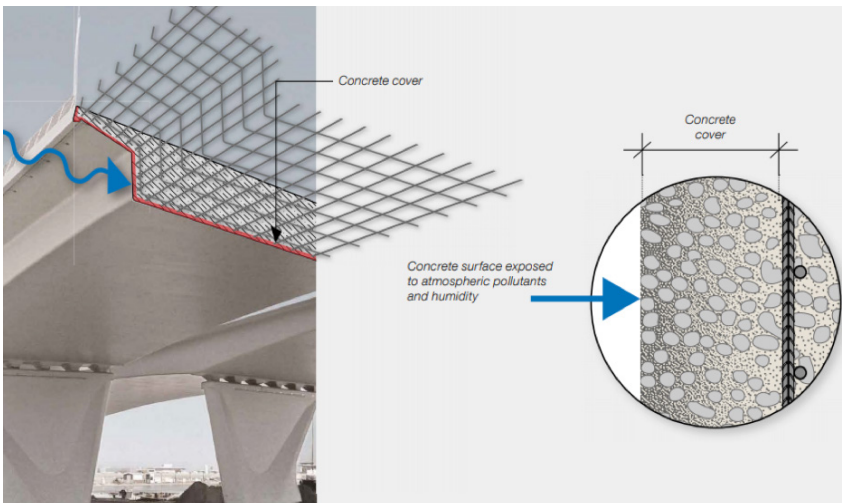

PRINCIPLES OF USE

1. Zemdrain® is fixed to the formwork before erection.

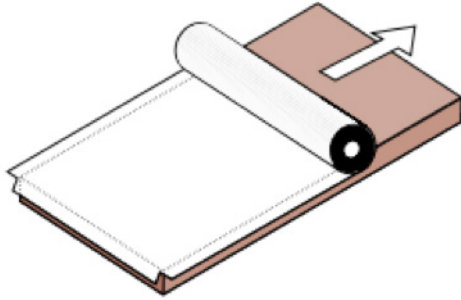

2. Once the formwork is erected, concrete is placed and compacted in accordance with normal practice.

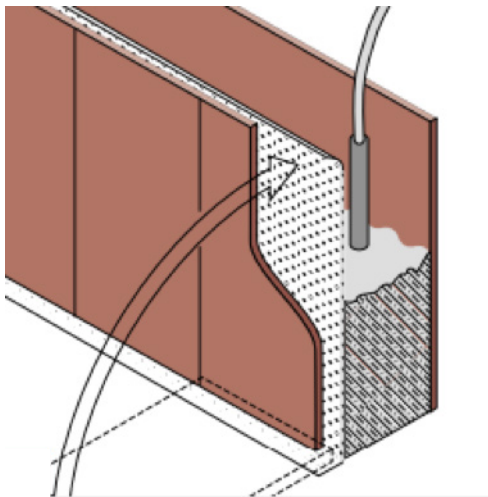

3. Zemdrain® retains the concrete fines whilst allowing the controlled drainage of excess air and water that is normally trapped at the concrete/formwork interface. Additionally, water retained within the formwork side of the formliner is given back to the concrete during the curing phase (early age curing of green concrete).

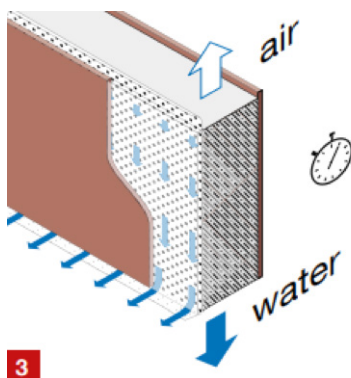

4. After removal of the formwork, the very dense, hard, virtually blowhole free surface uncontaminated by release agents produced with Zemdrain® is immediately visible.

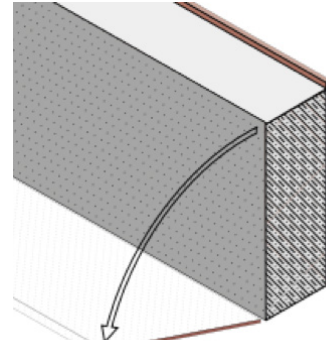

5. Use of Zemdrain® optimises the surface water/cement ratio, minimises blowholes and improves early age curing to give a high-quality durable concrete surface with optimum resistance to all forms of environmental attack.

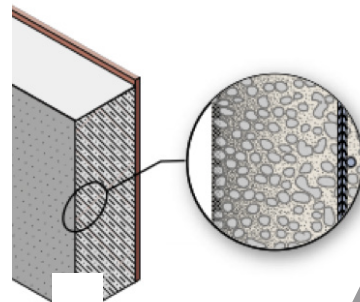

5

3

TECHNICAL DATA

Description	Filter fabric laminated to a plastic grid
Composition of filter	100 % polypropylene
Pore size of filter (EN ISO 12956)	71 µm
Area Weight	570 g/m ²
Thickness under 200 kPa	Not flammable
(BS EN ISO 9863-1)	1.45 mm
Compression under 0 to 200 kPa	15%
Tensile Strength M/X way	24.37 / 16.65 kN/m
Tensile Strength at 5 % elongation	kN/m
Mesh opening of drainage grid	4.5 mm
Air Permeability under 200 Pa	N/A
(EN ISO 9237)	220 mm/s
Drainage Capacity	up to 3 l/m ²
Water retention	0.75 l/m ²
Maximum water absorption of filter	N/A